



Digital Title Plan - DP 403966

Survey Number DP 403966
Surveyor Reference 4611
Surveyor Charles Hughes
Survey Firm C Hughes & Associates Ltd
Surveyor Declaration I Charles Hughes, being a person entitled to practise as a licensed cadastral surveyor, certify that -
(a) The surveys to which this dataset relates are accurate, and were undertaken by me or under my direction in accordance with the Cadastral Survey Act 2002 and the Surveyor-General's Rules for Cadastral Survey 2002/2;
(b) This dataset is accurate, and has been created in accordance with that Act and those Rules.
Declared on 02/09/2008.

Survey Details

Dataset Description Lots 1-3 being a subdivision of Lot 2 DP 307492
Status Deposited
Land District Otago
Submitted Date 02/09/2008
Survey Class Class I Cadastral Survey
Survey Approval Date 04/09/2008
Deposit Date 25/09/2008

Territorial Authorities

Central Otago District

Comprised In

CT 29018

Created Parcels

Parcels	Parcel Intent	Area	CT Reference
Lot 1 Deposited Plan 403966	Fee Simple Title	8.3217 Ha	413533
Lot 2 Deposited Plan 403966	Fee Simple Title	87.7921 Ha	413534
Lot 3 Deposited Plan 403966	Fee Simple Title	64.7436 Ha	413535
Marked A Deposited Plan 403966	Easement		
Marked B Deposited Plan 403966	Easement		
Marked C Deposited Plan 403966	Easement		
Marked D Deposited Plan 403966	Easement		
Marked E Deposited Plan 403966	Easement		
Marked F Deposited Plan 403966	Easement		
Marked G Deposited Plan 403966	Easement		
Total Area		<hr/> 160.8574 Ha	

<p>C. HUGHES & ASSOCIATES LTD </p> <p>Surveying and Resource Management Central Otago</p> <p>Cromwell Wanaka 17A Murray Tce, Tel 03 4450376 80 Ardmore St, Tel 03 443 5052 PO Box 51 Fax 03 4450375 PO Box 599 Fax 03 443 5062 cromwell@chasurveyors.co.nz wanaka@chasurveyors.co.nz</p>	<p>PLAN No.: DP 403966</p> <p>PLAN TITLE: Lots 1 - 3 being a Subdivision of Lot 2 DP 307492</p>
<p>Schedule / Memorandum</p>	

Memorandum of Easements			
Purpose	Shown	Servient Tenement	Dominant Tenement
Right to convey sewage	(A) (C)	Lot 2 hereon	Lot 1 hereon
Right to convey water	(E) (G)	Lot 2 hereon	Lot 1 hereon

Schedule of Existing Easements			
Purpose	Shown	Servient Tenement	Reference
Right of way	(B) (C) (D) (E) (F)	Lot 2 hereon	5323967.4

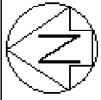

Diag. D
Non Primary

Lot 2 DP 390710

KAWARAU GORGE ROAD (SH 6)

CEMETERY ROAD

KAWARAU GORGE ROAD (SH 6)

Lot 1 DP 307492

2

T 2/3

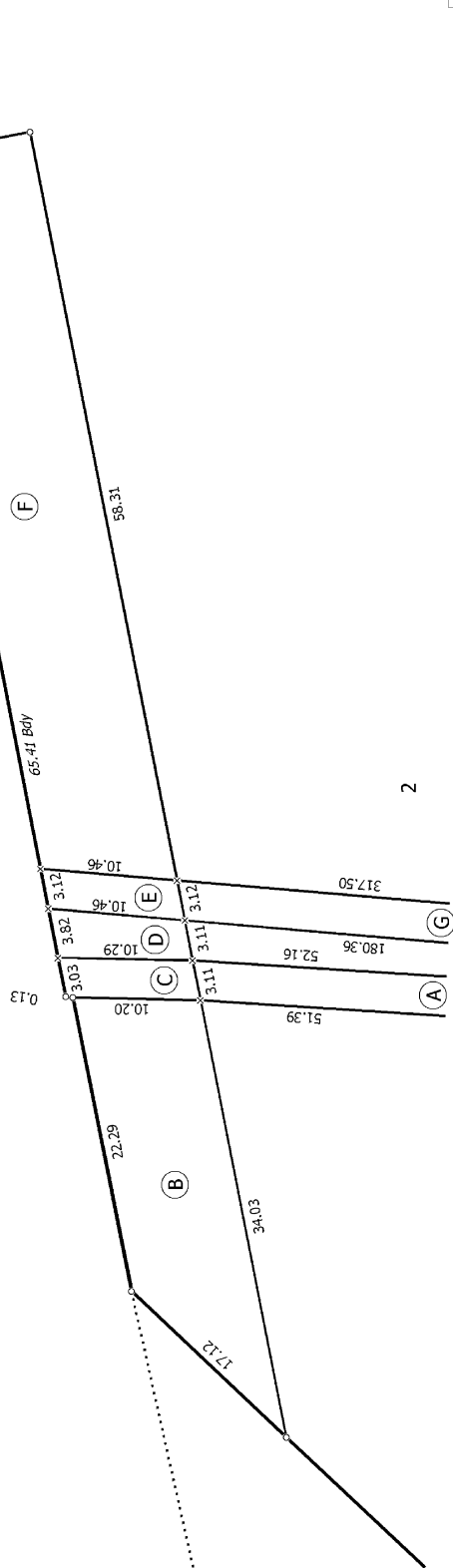

Land District: Otago

Digitally Generated Plan
Generated on: 25/09/2008 1:43pm Page 4 of 5

Lots 1-3 being a subdivision of Lot 2 DP 307492

Surveyor: Charles Hughes
Firm: C Hughes & Associates Ltd

Digital Title Plan
DP 403966

Deposited on: 25/09/2008

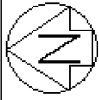

Diag. AA
Non Primary

CEMETERY ROAD

KAWARAU GORGE ROAD (SH 6)

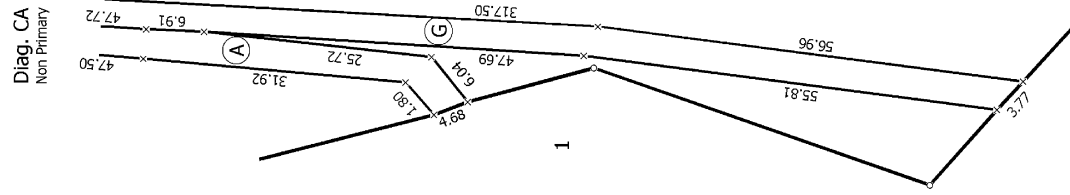
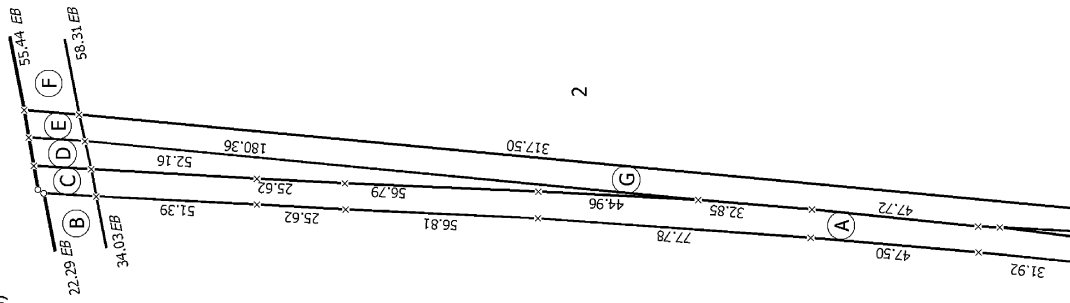

T 3/3

Digital Title Plan
DP 403966

Surveyor: Charles Hughes
Firm: C Hughes & Associates Ltd

Lots 1-3 being a subdivision of Lot 2 DP 307492

Land District: Otago
Digitally Generated Plan
Generated on: 25/09/2008 1:43pm Page 5 of 5

Deposited on: 25/09/2008